

Reg. No. _____

Name _____

APJ ABDUL KALAM TECHNOLOGICAL UNIVERSITY

THIRD SEMESTER B.TECH DEGREE EXAMINATION, JANUARY 2017

Course Code: EE 201

Course Name: CIRCUITS AND NETWORKS (EE)

Max. Marks: 100

Duration: 3 Hours

PART A

(Answer all questions. 5 Marks for each question)

- Using Superposition theorem, determine voltage V_2 for the circuit shown.

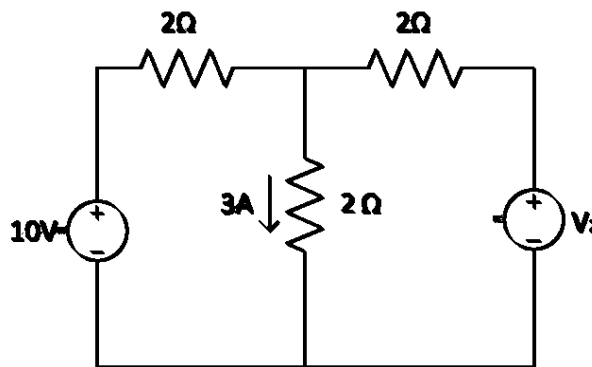

- Obtain basic cutset matrix for the network graph shown in figure and write down the network equations. Take 1,2,3 as tree branches.

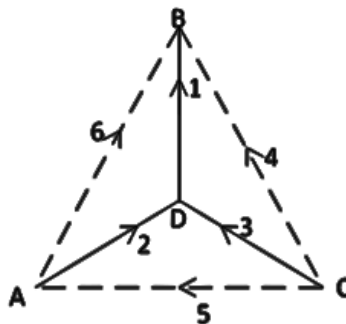

- What is the difference between transient analysis and steady state analysis of electrical network. Explain with suitable example.
- Write the mesh equations in s-domain for the network of figure, when a 10 V source is switched on. The primary and secondary self inductances are $L_1 = L_2 = 1$ H and $M = 0.5$ H

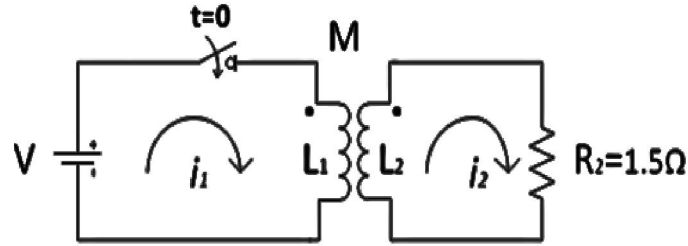

5. The port currents of a two port network are given by

$$I_1 = 2.5 V_1 - V_2$$

$$I_2 = -V_1 + 5 V_2$$

Find the equivalent π network.

6. Explain the symmetry and reciprocity property of a two port network. State the conditions for them in terms of different parameters.
7. Explain the properties of a positive real function
8. Describe the procedure of synthesizing the positive real function in First Cauer form of LC network.

PART B

(Answer any two Questions. 10 Marks for each question)

9. Use Thevenin's theorem to find the voltage across 3Ω resistor in figure.

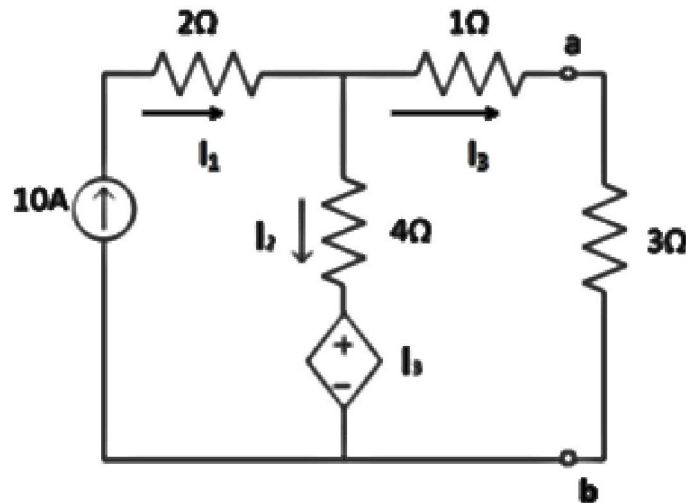

10. For the circuit shown, determine the load current I_L by using Norton's theorem.

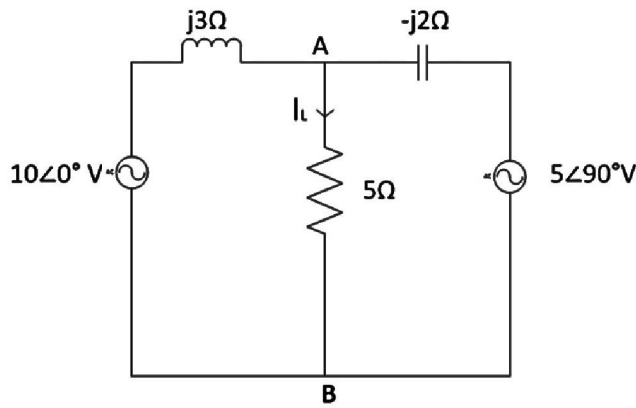

11. Calculate the loop currents using graph theory.

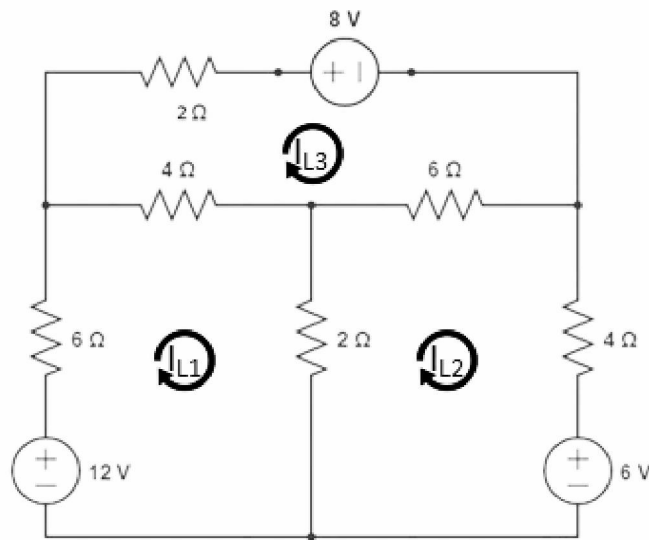

PART C

(Answer any two questions. 10 Marks for each question)

12. Find the response $i(t)$ in a series RLC circuit when a step input of V volts is applied across it at time $t = 0$. Assume all initial conditions as zero.
13. In the given circuit, capacitor C has an initial voltage $v_c(0^-) = 10$ volts and at the same instant, current in the inductor is zero. Switch k is closed at time $t = 0$. Obtain an expression for voltage across the inductor L .

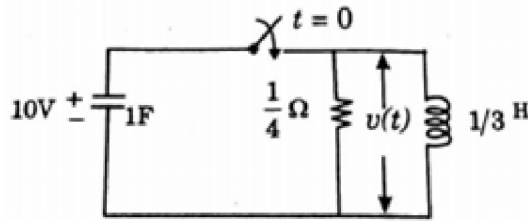

14. An RL series circuit is excited by sinusoidal voltage $v(t) = V_m \sin(\omega t + \Phi)$. Derive an expression for the current in the circuit. Discuss the factors which govern the maximum value and rate of decay of transient component of current.

PART D

(Answer any two questions. 10 Marks for each question)

15. a) What are transmission parameters? (2)
 b) Show that the overall transmission parameter matrix for cascaded 2 port network is simply the matrix product of transmission parameters for each individual 2 port network in cascade. (3)
 c) Find the second Foster form of LC network represented by

$$Y(s) = \frac{5s^2 + 1}{s(2s^2 + 1)} \quad (5)$$

16. Find the Z and Y parameters for the network shown in figure.

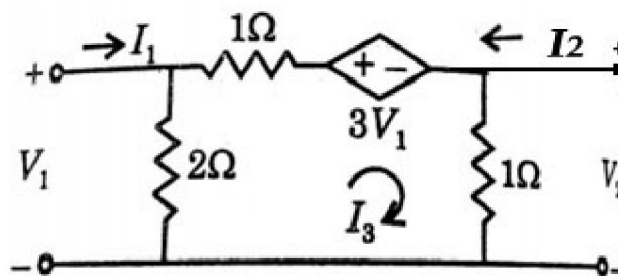

- 17 a) Differentiate between network analysis and synthesis. (4)
 b) Realize the given impedance function $Z(s)$ as a First Foster form

$$Z(s) = \frac{s^2 + 4s + 3}{s^2 + 6s + 8} \quad (6)$$